

Terminal Strip — TLB series — TLB-300W

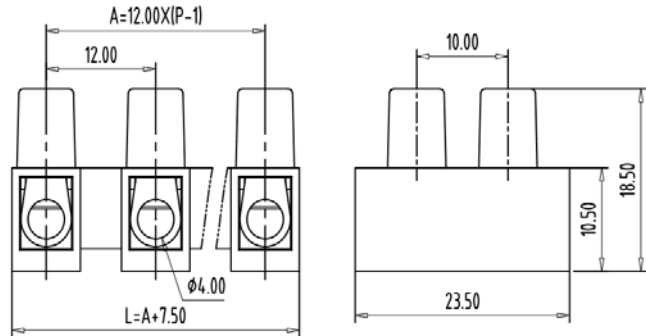
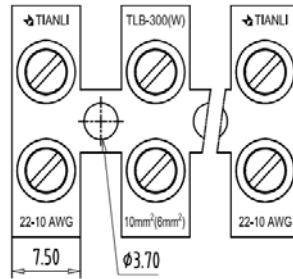

图示(Pic. shown) : TLB-300W-12P-T01S

General.	Terminal Strip Rated : 750V,41A , 6mm <sup>2</sup>
	12.00mm pitch , 02-12 Pole
	Wire-to-Wire Connection
	Screw clamp unit: M3.5, 0.8Nm Max

认证 ( Approval ) :



技术参数 Technical Data	UL standard			IEC standard		
	UL应用组别(UL Application group)	UL Application group			IEC过电压别/污染等级(IEC overvoltage category /pollution degree)	
IEC过电压别/污染等级(IEC overvoltage category /pollution degree)	B	C	D	III / 3	III / 2	II / 2
额定电压(Rated voltage)	300V	150V	300V	--	750V	--
额定电流(Rated current)	30A	30A	10A	--	41A	--
额定连接容量(Rated connection capacity)	22-10AWG Sol&Str			1.5-6mm <sup>2</sup>		
绝缘材料(Insulation Material)	PA66 UL94 V-2					
电流承载部件材料和镀层( Material & Plating of Current carrier )	Copper alloy , Ni plated					
接线弹片材料(Material of Clamp spring )	--					
绝缘电阻(Insulation Resistance)	500MΩ or more at DC500V					
耐电压(1分钟)(Withstanding Voltage/1Min)	3000V					
额定冲击电压(Rated surge voltage)	--					
接线螺丝(Wire clamp unit Screw) , 最大扭矩( torque Max. )	M3.5 , 0.8Nm Max					
固定螺丝(Mounting Screw) , 扭矩(torque)	--					
剥线长度(Wire stripping length)	8.0-9.0mm					
使用温度(Operating temperature)	-40°C up to +80°C					
焊接方式(Soldering recommend)	--					

订购方式(How to order)

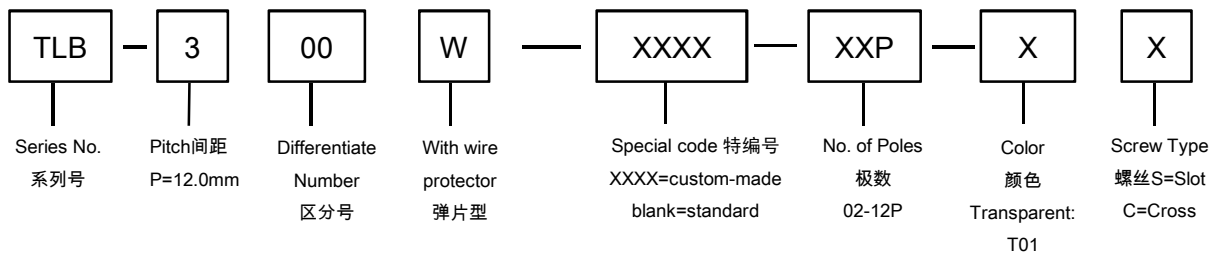

Web:www.china-tianli.com

TEL:+86-574-6347-9600,6389-6436

Mail : sale@china-tianli.cn

地址:中国浙江省宁波杭州湾新区庵东工业园区纬三路138号

ADD : 138 , Weisan Rd.,Andong Development Zone, Hangzhou Bay Area, Ningbo, Zhejiang, China